

ONE - PIPE - TR1

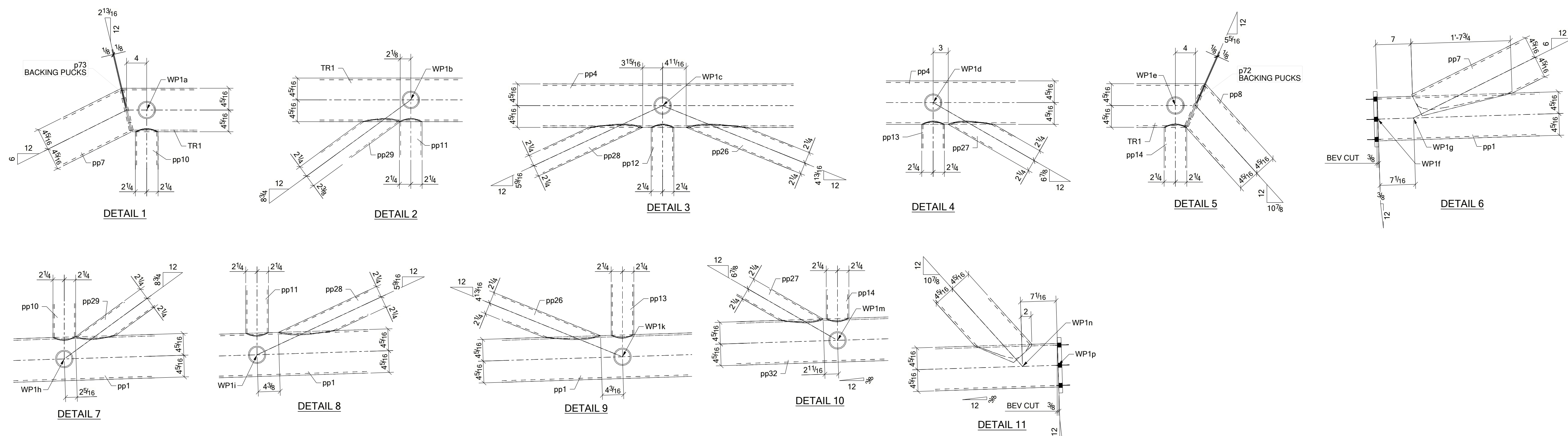

**BILL OF MATERIAL**

Assy Mark	Part Mark	TOTAL QTY.	DESCRIPTION	LENGTH FT. - INCH	WEIGHT IN lbs	MAT'L	REMARKS
TR1	ONE	PIPE					
	TR1	1	PIPE8STD	32'-4 3/16"	864	A53	
	p4	2	PL3/4X11	5'-3"	295	A36	
	p6	3	PL1/2X8 5/8	0'-11"	40	A36	
	p7	14	PL1/2X4 1/2	0'-8 5/8"	62	A36	
	p8	6	PL1/2X3	0'-5 1/4"	13	A36	
	p9	11	PL1/2X8	0'-8 5/8"	108	A36	
	p10	22	PL1/2X3	0'-3 3/4"	34	A36	
	p72	2	PL3/4X7 15/16	0'-8 9/16"	14	A36	
	p73	2	PL3/4X7 15/16	0'-8 1/8"	13	A36	
	pp1	1	PIPE8STD	46'-4 1/8"	1238	A53	
	pp4	1	PIPE8STD	32'-4 3/16"	864	A53	
	pp7	2	PIPE8STD	10'-11 1/4"	584	A53	
	pp8	2	PIPE8STD	4'-8 5/8"	252	A53	
	pp9	16	PIPE3STD	3'-4 1/8"	377	A53	
	pp10	2	PIPE4STD	3'-11 13/16"	80	A53	
	pp11	2	PIPE4STD	3'-9 7/16"	76	A53	
	pp12	2	PIPE4STD	3'-5 15/16"	70	A53	
	pp13	2	PIPE4STD	3'-2 3/8"	64	A53	
	pp14	2	PIPE4STD	3'-0"	60	A53	
	pp21	1	PIPE2STD	5'-2 3/16"	18	A53	
	pp25	1	PIPE2STD	4'-9 3/16"	17	A53	
	pp26	2	PIPE4STD	9'-2 9/16"	186	A53	
	pp27	2	PIPE4STD	6'-5 11/16"	130	A53	
	pp28	2	PIPE4STD	9'-5 13/16"	191	A53	
	pp29	2	PIPE4STD	7'-0 7/8"	142	A53	
	pp31	9	PIPE3STD	4'-4 5/8"	278	A53	
	pp32	1	PIPE8STD	46'-4 1/8"	1238	A53	
	pp33	1	PIPE6STD	11'-1 9/16"	197	A53	
	pp34	1	PIPE6STD	5'-7 15/16"	100	A53	
	pp46	1	PIPE3STD	5'-5 3/16"	38	A53	
	pp47	1	PIPE3STD	5'-3 7/16"	37	A53	
	pp48	1	PIPE3STD	5'-0 7/8"	36	A53	
	pp49	1	PIPE3STD	4'-10 3/8"	34	A53	
	pp50	1	PIPE3STD	4'-8 5/8"	33	A53	
	pp51	1	PIPE2STD	5'-3 15/16"	19	A53	
	pp52	1	PIPE2STD	5'-1 3/8"	18	A53	
	pp53	1	PIPE2STD	4'-11 5/8"	17	A53	
	pp54	1	PIPE2STD	4'-10 13/16"	17	A53	
	pp60	1	PIPE3STD	4'-4 5/8"	31	A53	
TOTAL WEIGHT THIS DRAWING					7889		

STD NOTE:  
INSIDE CORNERS OF ALL COPES AND CUTS TO BE 1/2" RAD. MIN. U.N.

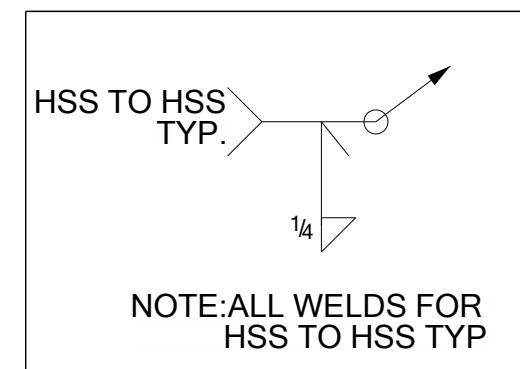

DETAILS THIS SHEET APPLY TO UPPER AND LOWER MEMBERS OF THIS TRUSS  
REFER TO SHEET TR1-B AND TR1-C



DWG. ISSUE	REVISIONS	BOLTS	HOLES	STEEL WF (ASTM)	HSS (ASTM)	PARTS (ASTM)
DATE	PURPOSE	NO.	DATE	DESCRIPTION		
06/04/2021	FOR APVL	A	06/04/2021	APVL		
06/22/2021	FOR FAB	B	06/22/2021	FAB		

FINISH:	U.N.O	U.N.O	A992	A500-GR.B	A36	A36
CUSTOMER:	SHOP STD. GRAY		SSPC-SP2		1.5-2.0 MILS	
PROJECT:	CHAC UNITED SAMPLE DRAWING					
ADDRESS:	CHAC UNITED SAMPLE DRAWING					
DRAWN BY:						CHECKED BY:
					SHEET NO:	