

ONE - BEAM - 03B134

W24X94
d 24 1/4"
tw 1/2"
bf 9 1/8"
tf 7/8"
k 1 3/4"
SD 5 1/2"

BILL OF MATERIAL

Assy	Part	TOTAL	DESCRIPTION	LENGTH	WEIGHT	MAT'L	REMARKS
Mark	Mark	QTY.		FT. - INCH	IN lbs		
03B134		ONE	BEAM				
	03B134	1	W24X94	22'-1"	2082	A992	
	ST3	1	PL3/8X4 1/2	0'-8 1/2"	4	A36	
	p1052	1	PL1/2X13 15/16	4'-0"	89	A36	
TOTAL WEIGHT THIS DRAWING					2175		

STD NOTE:
INSIDE CORNERS OF ALL COPES AND CUTS TO BE 1/2" RAD. MIN. U.N.

DK.	GRID LOC.	ELEV.
03	G-H/3	T.O.S 12'-5 1/4"

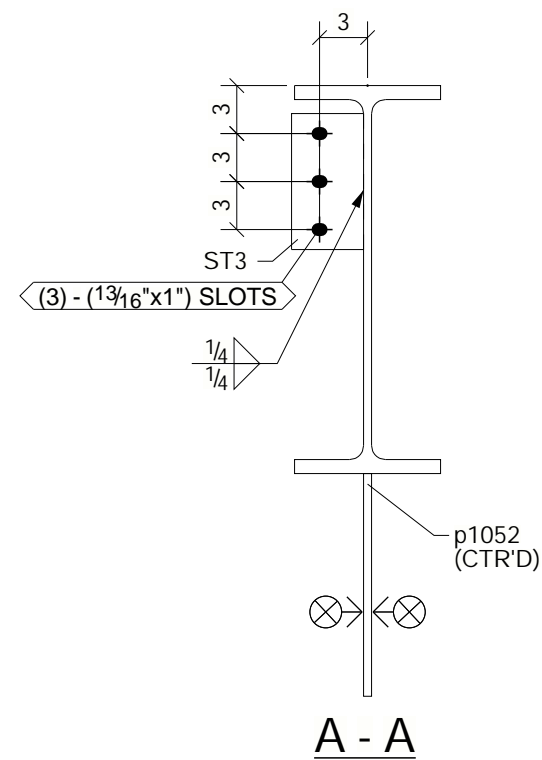

DWG. ISSUE	DATE	PURPOSE	NO.	DATE	DESCRIPTION
	04/18/2022	FOR APVL	△		
			△		
			△		
			△		
			△		
			△		
			△		
			△		

BOLTS A325 U.N.O	HOLES 13/16"Ø U.N.O	STEEL WF (ASTM) A992	HSS (ASTM) A500-GR.B	PARTS (ASTM) A36 U.N.O
FINISH: NO PAINT		SURFACE PREP: SSPC-SP2		DRY FILM THICKNESS 1.5-2.0 MILS
CUSTOMER:			RD = REF. PT FOR RD'S	WELDING: E70XX-LH
PROJECT: CHAC UNITED SAMPLE DRAWING				
DRAWN BY:			CHECKED BY:	
JOB NO:			SHEET NO:	

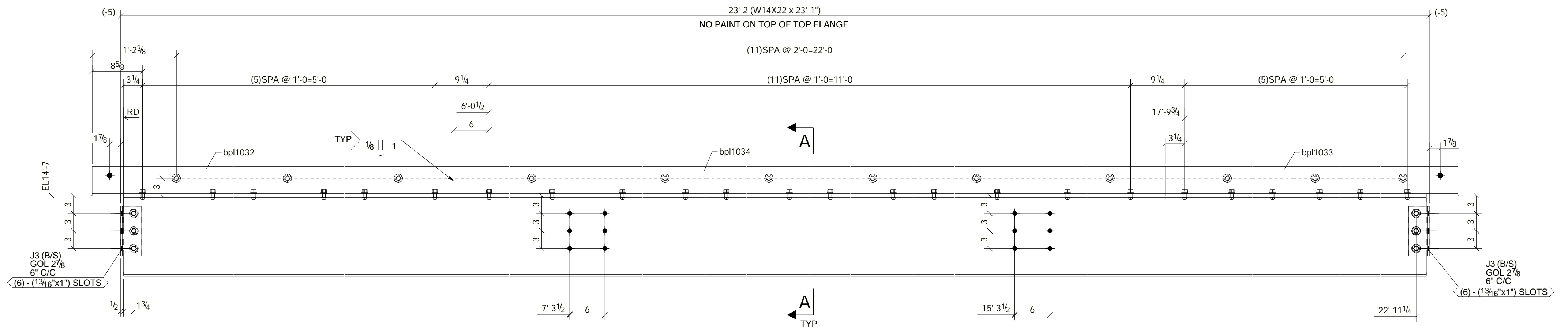

ONE - BEAM - 04B137

SHOP NOTES	
1.)	NO PAINT ON TOP OF TOP FLANGE AND INSIDE FACE OF POUR STOP PLATE.
2.)	KEEP 1/2" Ø BOLTS HEAD BELOW AND WRENCH TIGHT BOLTS

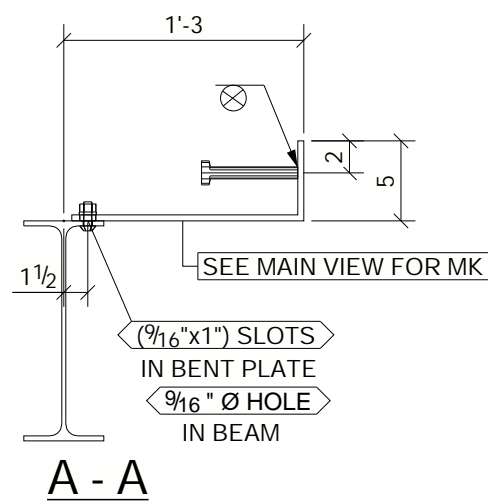

BILL OF MATERIAL

Assy Mark	Part Mark	TOTAL QTY.	DESCRIPTION	LENGTH FT. - INCH	WEIGHT IN lbs	MAT'L	REMARKS
04B137		ONE	BEAM				
	04B137	1	W14X22	23'-1"	510	A992	
	J3	4	L4X3-1/2X5/16	0'-8 1/2"	22	A36	
	bpl1032	1	BPL3/8X18 3/4	5'-11 7/8"	143	A36	BENT
	bpl1033	1	BPL3/8X18 3/4	5'-11 7/8"	143	A36	BENT
	bpl1034	1	BPL3/8X18 3/4	12'-0"	293	A36	BENT
	ns1000	12	WS_3/4-DIA	0'-6"	11	A108	
		24	1/2" Ø A325N_TC BOLT	0'-1 1/2"	5		
		6	3/4" Ø A325N_TC BOLT	0'-2"	4		
TOTAL WEIGHT THIS DRAWING					1130		

STD NOTE:
INSIDE CORNERS OF ALL COPES AND CUTS TO BE 1/2" RAD. MIN. U.N.

Dk.	GRID LOC.	ELEV.
04	1/F-D.8	T.O.S. 14'-7"

W14X22
d 13 3/4"
tw 1/4"
bf 5"
tf 5/16"
k 1 1/16"
rw 2 3/4"

DWG. ISSUE		REVISIONS		
DATE	PURPOSE	NO.	DATE	DESCRIPTION
01/05/2022	FOR APVL	A	01/05/2022	APVL
02/10/2022	FOR FAB	0	02/10/2022	FAB

BOLTS A325 U.N.O	HOLES 13/16 Ø U.N.O	STEEL WF (ASTM) A992	HSS (ASTM) A500-GR.C	PARTS (ASTM) A36 U.N.O
FINISH: SHOP STD. PRIMER		SURFACE PREP: SSPC-SP2		DRY FILM THICKNESS 1.5-2.0 MILS
CUSTOMER:			RD = REF. PT FOR RD'S	WELDING: E70XX-LH
PROJECT: CHAC UNITED SAMPLE DRAWING				
DRAWN BY:			CHECKED BY:	
JOB NO:			SHEET NO:	

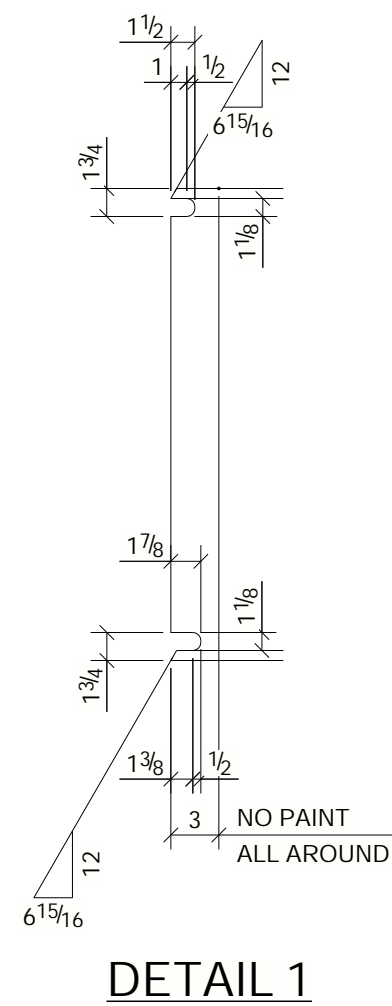
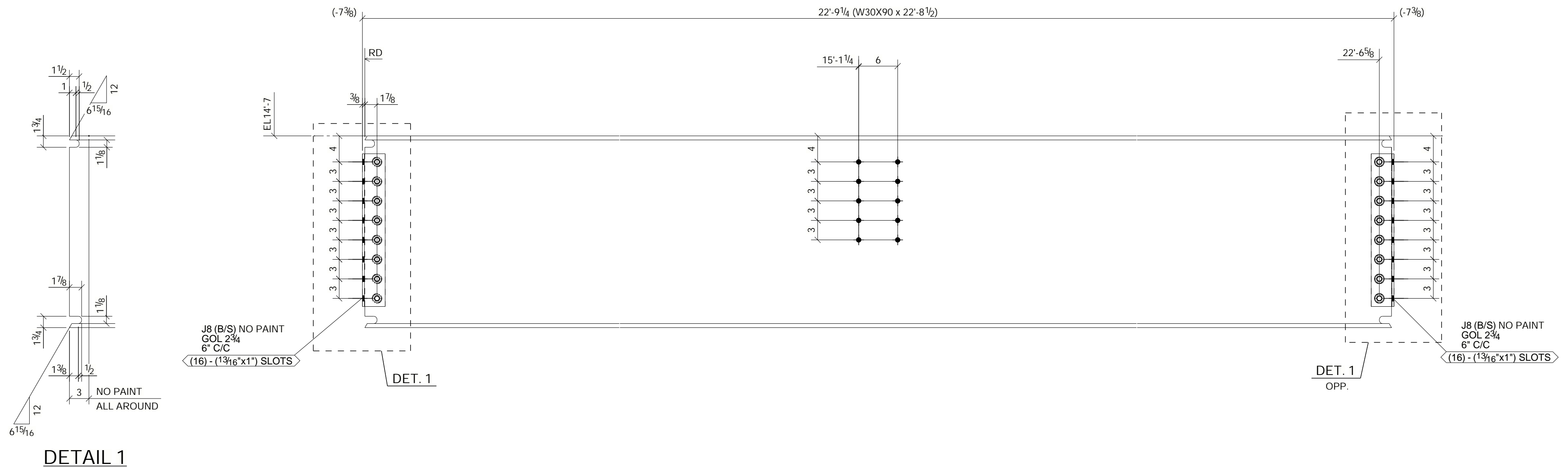

ONE - BEAM - 04B154

BILL OF MATERIAL

Assy	Part	TOTAL	DESCRIPTION	LENGTH	WEIGHT	MAT'L	REMARKS
Mark	Mark	QTY.		FT. - INCH	IN lbs		
04B154		ONE	BEAM				
	04B154	1	W30X90	22'-8 1/2"	2032	A992	
	J8	4	L4X3-1/2X5/16	1'-11 1/2"	60	A36	
		16	3/4"Ø A325SC_TC BOLT	0'-2 1/4"	10		NO PAINT WITHIN 3in.
TOTAL WEIGHT THIS DRAWING					2102		

STD NOTE:
INSIDE CORNERS OF ALL COPES AND CUTS TO BE 1/2" RAD. MIN. U.N.

Dk.	GRID LOC.	ELEV.
04	2/D.8-C.7	T.O.S. 14'-7"

W30X90
d 29 1/2"
tw 1/2"
bf 10 3/8"
tf 5/8"
k 1 1/2"
kw 5 1/2"

DWG. ISSUE		REVISIONS		
DATE	PURPOSE	NO.	DATE	DESCRIPTION
01/05/2022	FOR APVL	A	01/05/2022	APVL
02/10/2022	FOR FAB	Ø	02/10/2022	FAB

BOLTS A325 U.N.O	HOLES 13/16Ø U.N.O	STEEL WF (ASTM) A992	HSS (ASTM) A500-GR.C	PARTS (ASTM) A36 U.N.O
FINISH: SHOP STD. PRIMER		SURFACE PREP: SSPC-SP2		DRY FILM THICKNESS 1.5-2.0 MILS
CUSTOMER:			RD = REF. PT FOR RD'S	WELDING: E70XX-LH
PROJECT: CHAC UNITED SAMPLE DRAWING				
DRAWN BY:			CHECKED BY:	
JOB NO:			SHEET NO:	

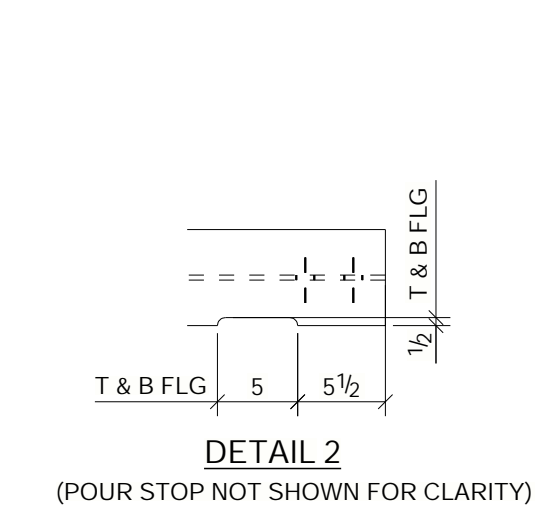
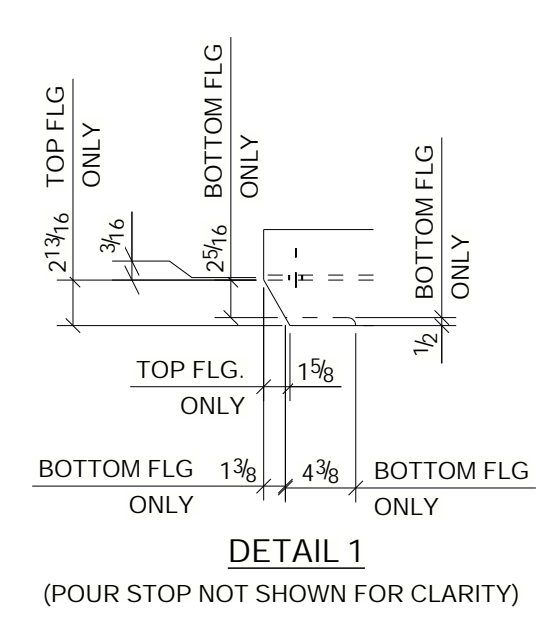
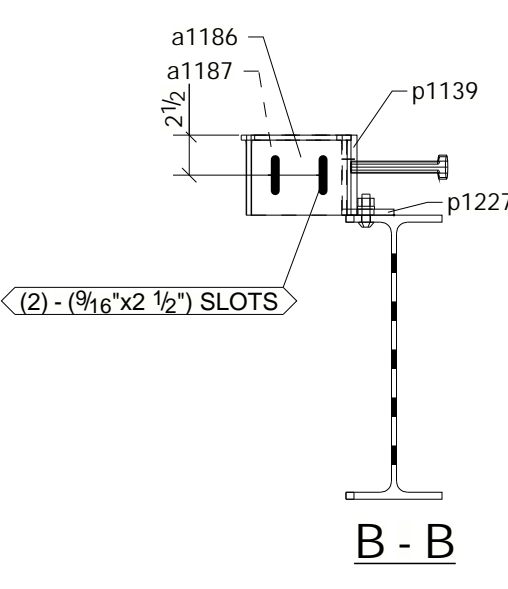
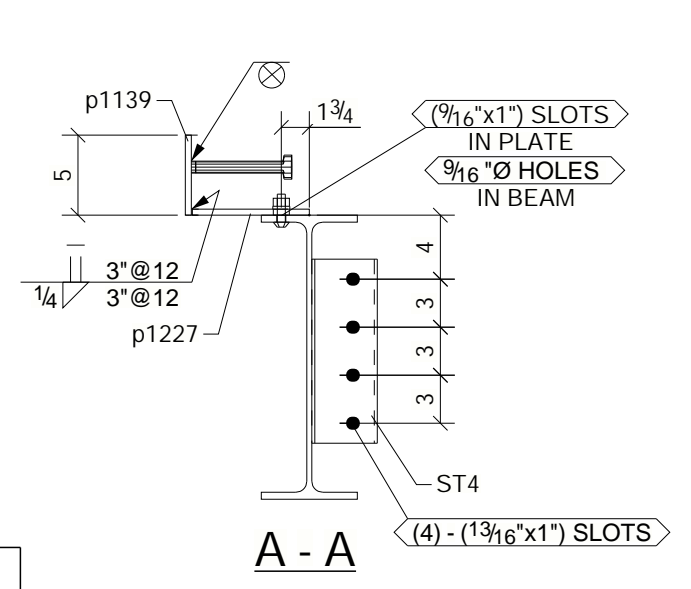
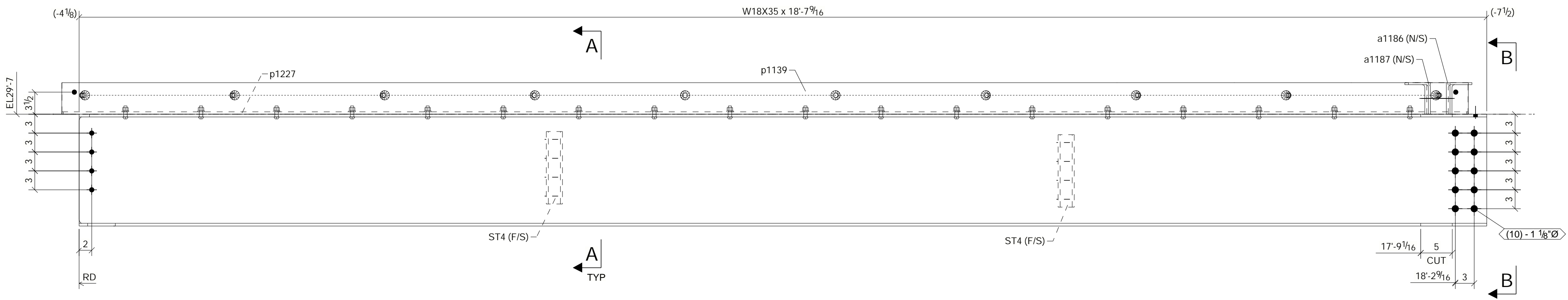
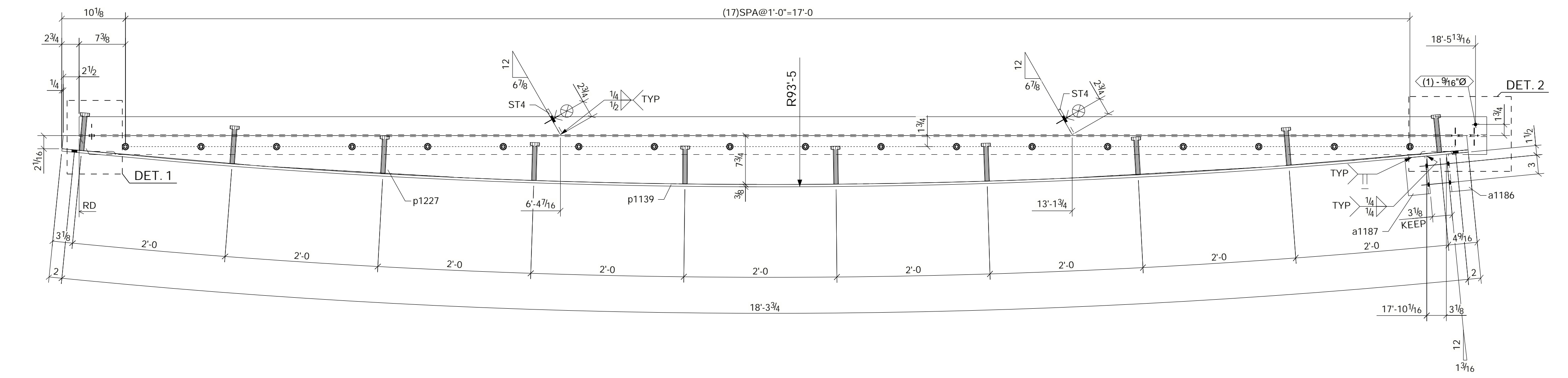

ONE - BEAM - 05B183

SHOP NOTES	
1.)	NO PAINT TOP OF TOP FLANGE AND INSIDE FACE OF POUR STOP PLATE.
2.)	KEEP 1/2\"/>

BILL OF MATERIAL

Assy Mark	Part Mark	TOTAL QTY.	DESCRIPTION	LENGTH FT. - INCH	WEIGHT IN lbs	MAT'L	REMARKS
05B183		ONE	BEAM				
	05B183	1	W18X35	18'-7 9/16"	653	A992	
	ST4	2	PL3/8X4 1/2	0'-11 1/2"	11	A36	
	a1186	1	L5X3-1/2X5/16	0'-6"	4	A36	
	a1187	1	L5X3-1/2X5/16	0'-6"	4	A36	
	ns1000	10	WS_3/4-DIA	0'-6"	9	A108	
	p1139	1	PL3/8X5	18'-7 3/4"	119	A36	
	p1227	1	PL3/8X7 5/8	18'-7 5/16"	138	A36	
		18	1/2\"/>				

TOTAL WEIGHT THIS DRAWING 943

STD NOTE:
INSIDE CORNERS OF ALL COPES AND CUTS TO BE 1/2" RAD. MIN. U.N.

Dk.	GRID LOC.	ELEV.
05	1-1.8/G.8-G.3	T.O.S. 29'-7"

W18X35
d 17 3/4"
tw 5/16"
bf 6"
tf 7/16"
k 1 1/8"
rs 3 1/2"

DWG. ISSUE		REVISIONS		
DATE	PURPOSE	NO.	DATE	DESCRIPTION
01/05/2022	FOR APVL	A	01/05/2022	APVL

BOLTS A325 U.N.O	HOLES 13/16\"/>	
STEEL WF (ASTM) A992	HSS (ASTM) A500-GR.C	PARTS (ASTM) A36 U.N.O
FINISH: SHOP STD. PRIMER		SURFACE PREP: SSPC-SP2
CUSTOMER:		DRY FILM THICKNESS 1.5-2.0 MILS
PROJECT:		RD = REF. PT FOR RD'S
ADDRESS:		WELDING: E70XX-LH
CHAC UNITED SAMPLE DRAWING		
DRAWN BY:		CHECKED BY:
JOB NO:		SHEET NO: